



Condair EC

Änderungen vorbehalten!

Subject to change!

Modifications réservées!

Pos	Artikel/Article/Article	Heizspannung Heating voltage Tension de chauffage		230V/1		230V/3		400V/3		230V/3		400V/3		Art./SAP-No.
		5 + 8	5 + 8	5 + 8	15	15	23	23	32	32 + 45				
100	Steuerelektronik Control PCB Unité de commande													2548564
101	Leistungspriint Power board Platine de puissance													2548565
102	Netzschalter Power switch Interrupteur du réseau													2530137
103	Betriebs- und Störungsfernmeldung Remote operation and fault indication Télésignalisation de travail et de dérangement													2546682
104	Schütz Contactor Contacteur	25 A		1	1		1							1115507
		50 A	1			1		1						1115511
		65 A											1	1115809
		80A										1		1117502
		110 A										1		1117504
105	Erdungsklemme Earth terminal Bloc de terre	10mm <sup>2</sup>	1	1	1	1	1							2530794
		16mm <sup>2</sup>						1	1			1		2530795
		35mm <sup>2</sup>										1		2553359
106	Erdelektrode Earth electrode Electrode de terre		1	1	1	1	1	1	1	1	1	1	1	2548573
107	Schlauchset Einlass Hose set inlet Set de tuyau d'alimentation		1	1	1	1	1			1	1	1	1	2548579
														2548580
108	Schlauchset Hose set Set de tuyau		1	1	1	1	1			1	1	1	1	2548587
														2548588
109	Schlauchklemme ø23.5-24.7, 5 Stk. Hose clamp ø23.5-24.7, 5 pcs Pince à tuyau ø23.5-24.7, 5 pcs		x	x	x	x	x	x	x	x	x	x	x	2548616
110	Schlauchklemme ø19.6-20.6, 5 Stk. Hose clamp ø19.6-20.6, 5 pcs Pince à tuyau ø19.6-20.6, 5 pcs		x	x	x	x	x	x	x	x	x	x	x	2519409
111	Schlauchbride ø23/9, 5 Stk. Screw hose clamp ø23/9, 5 pcs Collier de serrage ø23/9, 5 pcs		x	x	x	x	x	x	x	x	x	x	x	2548615
112	Einlassventil Inlet valve Vanne de remplissage	0.5 l/min.	1	1	1									2546673
		1.2 l/min.					1	1						2546674
		2.5 l/min.							1	1	1	1		2546675
113	Einlassbecher Filling cup Godet de remplissage		1	1	1	1	1	1	1	1	1	1	1	1115828
114	Auslassventil kpl. Outlet solenoid valve cpl. Vanne d'écoulement cpl.	200-240V, 50/60Hz	1	1	1	1	1	1	1	1	1	1	1	1116962
115	O-Ring, 10 Stk. O-ring seall, 10 pcs Joint O-ring, 10 pcs		x	x	x	x	x	x	x	x	x	x	x	1102867



Pos	Artikel/Article/Article	Heizspannung Heating voltage Tension de chauffage	230V/1	230V/3	400V/3	230V/3	400V/3	400V/3	230V/3	230V/3	400V/3	Art.-/SAP-No.
			Dampfleistung [kg/h] Steam capacity [kg/h] Capacité de vapeur [kg/h]	5 + 8	5 + 8	5 + 8	15	15	23	23	32	
200	Sensorstecker mit Kabel Sensor plug with cable Fiche de connexion du senseur avec câble	ø 5mm	1	1	1	1	1	1	1	1	1	1115822
201	Kabelbaum kpl. Cable tree cpl. Faisceau de câble cpl.		1	1	1	1	1	1	1	1	1	2530830 2530098 2530099 2530100 2530102 2530103 2553358
202	Dampfzylinderstecker, 3 Stk. Cylinder plug, 3 pcs Fiche de connexion du cylindre, 3 pcs	ø 5mm ø 6mm ø 6mm	1	1	1	1	1	2	2	2	2	1102495 1101868 1117283
203	Klammern zu reinigbarem Dampfzylinder, 4 Stk. Clip to cleanable steam cylinder, 4 pcs Clip pour cyl. à vapeur nettoiyable, 4 pcs		x	x	x	x	x	x	x	x	x	1115790
204	O-Ring zu reinigbarem Dampfzylinder O-ring seal to cleanable steam cylinder O-ring pour cylindre à vapeur nettoiyable	D301 D401 D601	x	x	x	x	x	x	x	x	x	1115787 1115788 1115789
205	Dichtungsring zu reinigbarem Dampfzylinder, 4 Stk. Seal ring to cleanable steam cylinder, 4 pcs Joint ring pour cylindre à vapeur nettoiyable, 4 pcs		x	x	x	x	x	x	x	x	x	1102225
206	Elektroden-Set (ohne Schikane) Set electrodes (without divider) Set electrodes (sans chicane de separation)	E342 (D342) E343 (D343/363) E444 (D444/464) E644 (D644/664) E654 (D654/674)	1	1	1	1	1	1	1	1	1	1115779 1115780 1115781 1115782 1115783
207	Schikanen zu reinigbarem Dampfzylinder Divider to cleanable steam cylinder Chicane de séparation pour cylindre à vapeur nettoiyable	D363 D464 D664/674			x		x	x			x	1115784 1115785 1115786
208	Sieb zu reinigbarem Dampfzylinder Strainer to cleanable steam cylinder Filtre de séparation pour cylindre à vapeur nettoiyable	3-600	x	x	x	x	x	x	x	x	x	1106695
209	Austauschzylinder Exchange cylinder Cylindre à échanger	A342 A343 A363 A444 A464 A644 A664 A674	1	1	1	1	1	1	1	1	1	5020006 5020007 5020010 5020012 5020014 5020021 5020024 5020025
210	Reinigbare Zylinder mit Elektroden Cleanable steam cylinder with electrodes Cylindre nettoiyable avec électrodes	D342 D343 D363 D444 D464 D644 D664 D674	x	x	x	x	x	x	x	x	x	5020032 5020033 5020036 5020037 5020038 5020039 5020041 5020042
211	Reinigbarer Dampfzylinder (leer) Cleanable steam cylinder (empty) Cylindre à vapeur nettoiyable (vide)	D301 D401 D601	x	x	x	x	x	x	x	x	x	1115776 1115777 1115778

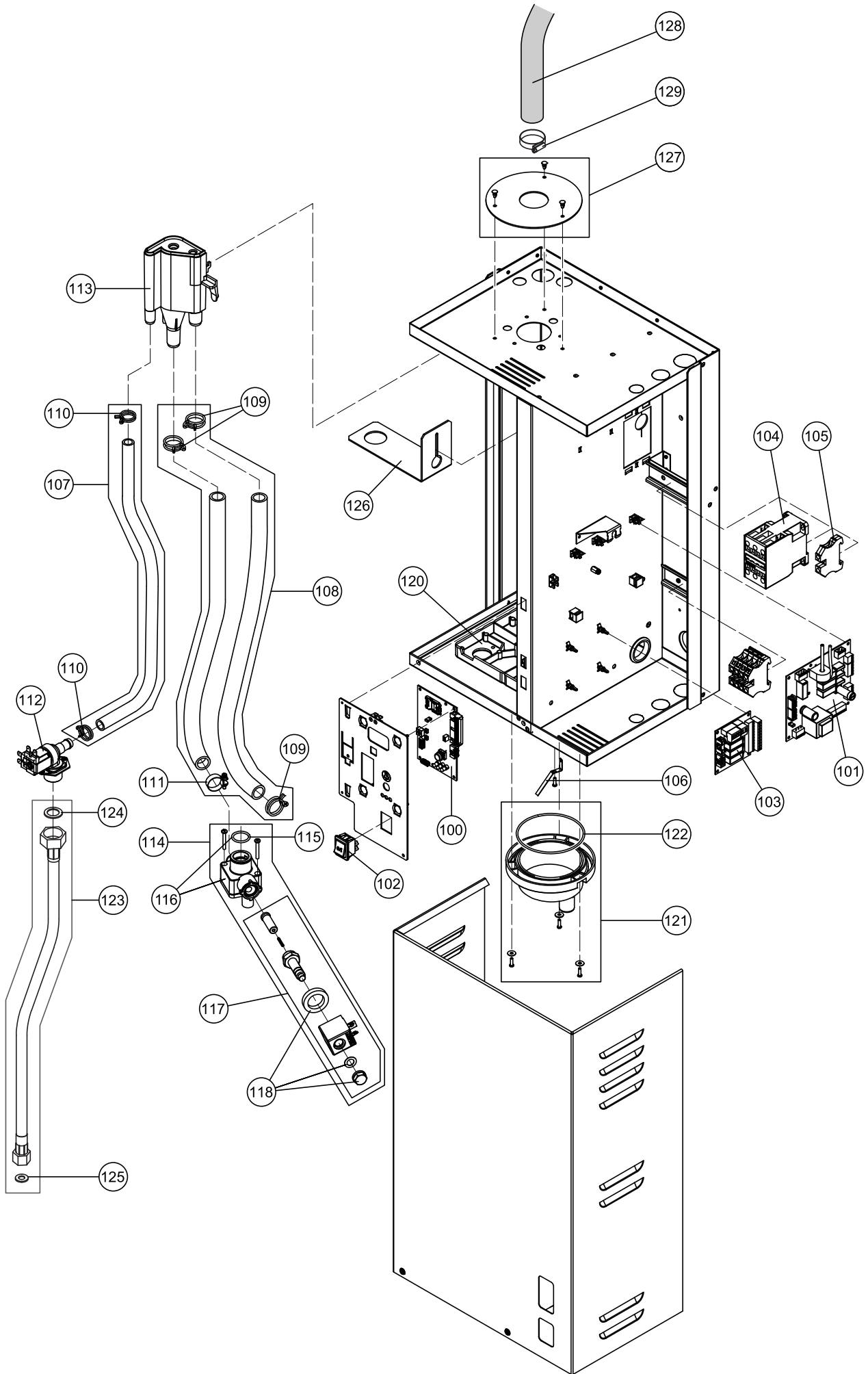

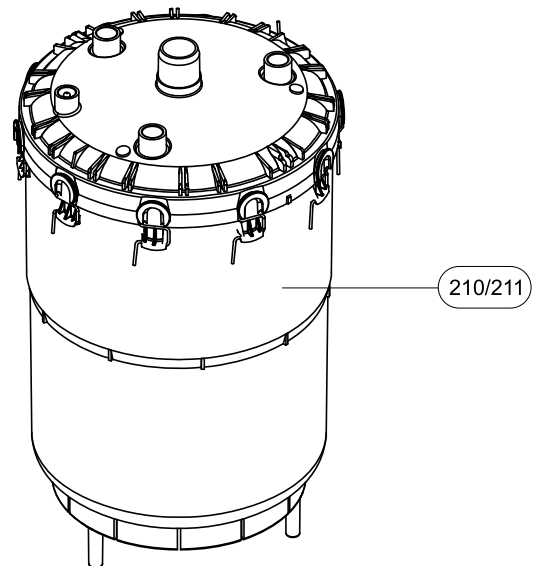
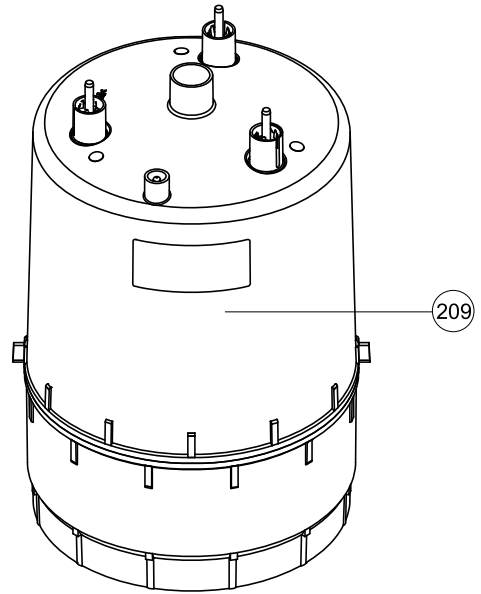
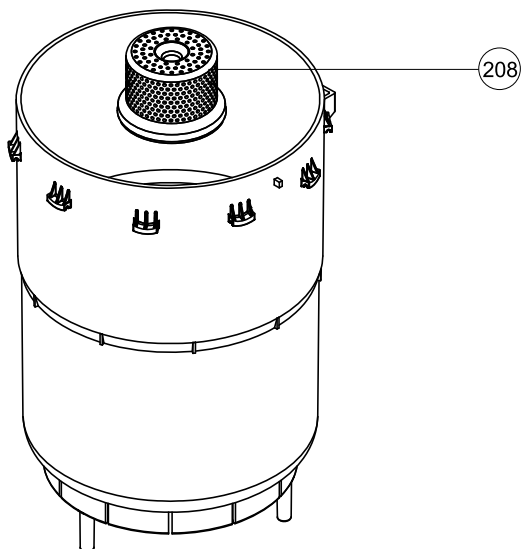
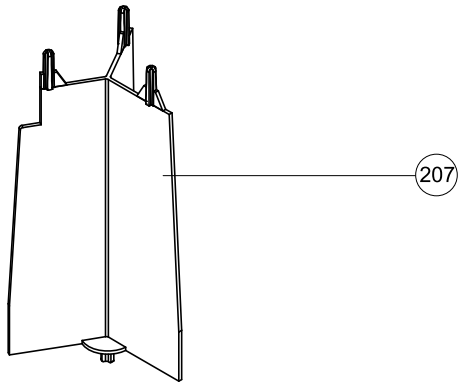
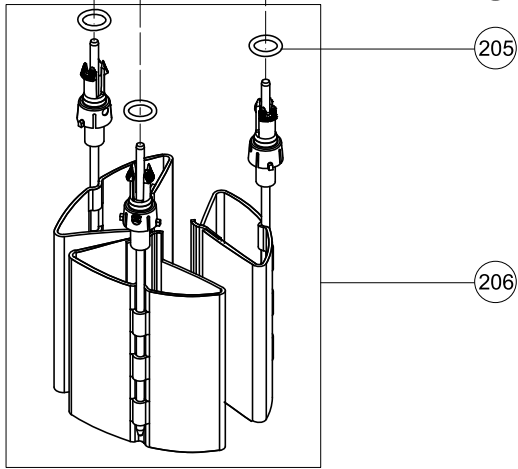
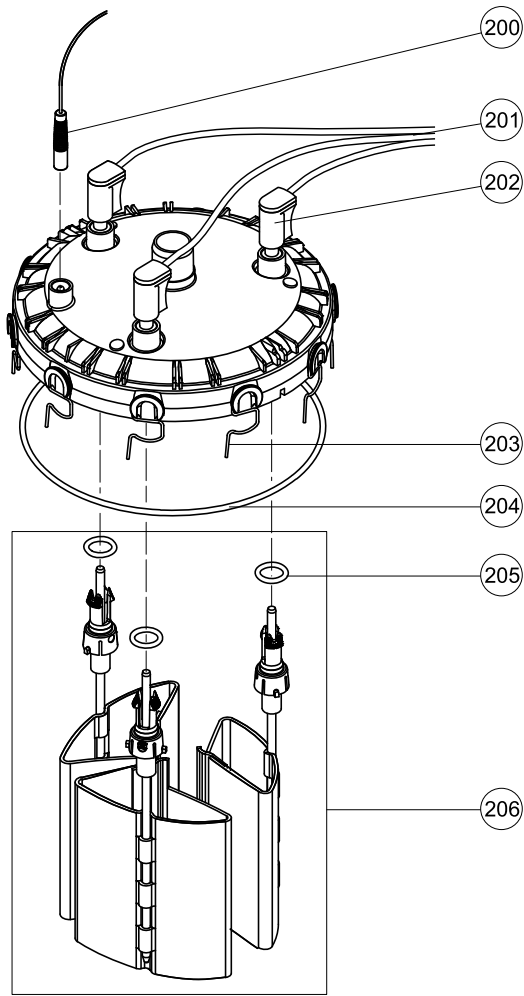



CH94/0002.00

Condair Group AG  
Gwattstrasse 17, 8808 Pfäffikon SZ, Switzerland  
Phone +41 55 416 61 11, Fax +41 55 588 00 07  
info@condair.com, www.condairgroup.com

The Condair logo, consisting of a stylized graphic of three wavy lines to the left of the word 'condair' in a bold, lowercase, sans-serif font.